

(Poster at FENS'2000, Brighton, UK)

Is Working Memory Stochastic ?

Guido Bugmann

Centre for Neural and Adaptive Systems, Plymouth, UK

<http://www.tech.plym.ac.uk/soc/staff/GuidBugm/>

Abstract:

Behavioural experiments show that retention in working memory (WM) degrades with time (Bauer & Fuster, 1976; Fuster et al., 1981; Ploner et al., 1998; Rubin et al., 1999). The present work proposes an explanation at the neuronal level for such degradation. It is known that (i) most WM neurones in prefrontal cortex (PFC) show a constant firing rate during the delay period (Miller et al., 1996), (ii) sustained firing does sometimes end prematurely and (iii) does sometimes fail to start (Funahashi et al., 1989). It is proposed here WM neurones are part of a reverberating circuit in which initiation and ending of sustained firing is probabilistic, reflecting the probabilistic nature of synaptic transmission. Here the probability to find a WM neurone in an active state decreases exponentially with time but the activity of the neurone stays constant while it lasts. This stochastic working memory model allows reproducing the probabilistic behavior and the pattern of errors of subjects in three working memory experiments: (i) Delayed Matching to Sample (DMS) tasks, (ii) Relative Recency Discrimination task

(RRD) and (iii) Oculomotor Delayed Response tasks (ODR). A good fit to experimental data is generally obtained with PFC memory decay constants of less than a minute. Data from subjects with PFC lesions are reproduced when retention times are reduced to 1/3 of normal values. The results also suggest that a small number of working memory neurons are active at any time when storing a sensory cue. Fitting the data constrains the relations between the parameters of the model, but does not provide unique solutions. Parameters include the encoding efficiency (from inferior temporal cortex (IT) to PFC), the number of neurons in IT and PFC representing an item and the retention time. To narrow down the number of possible solutions, further data are needed on the statistical and dynamic properties of memory neurons in PFC.

Working Memory Neurones:

(Funahashi et al., 1989)

Neuron 5018

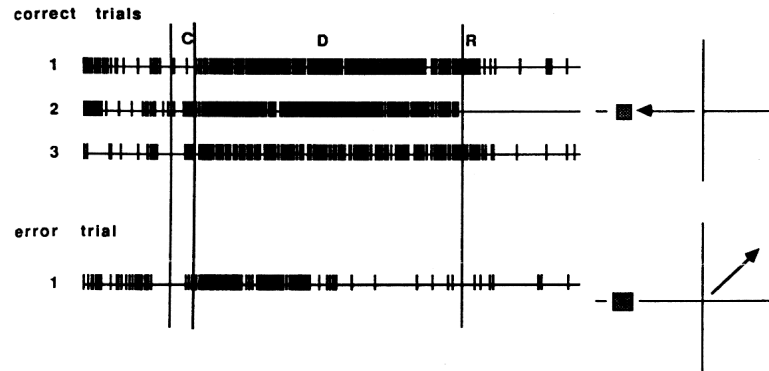

Sometimes stop prematurely

Neuron 5111

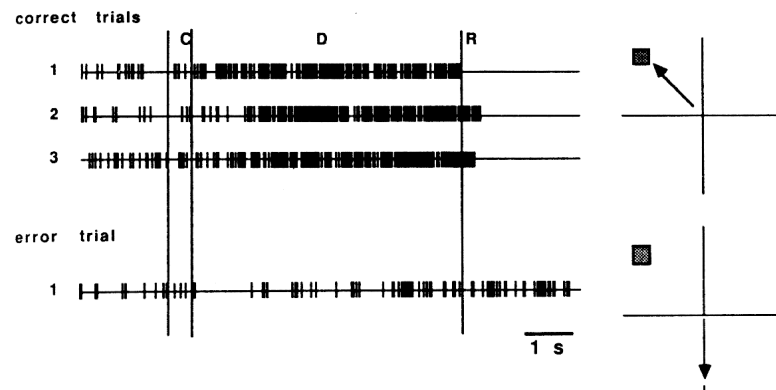

Sometimes fail to start

Stochastic Model of WM

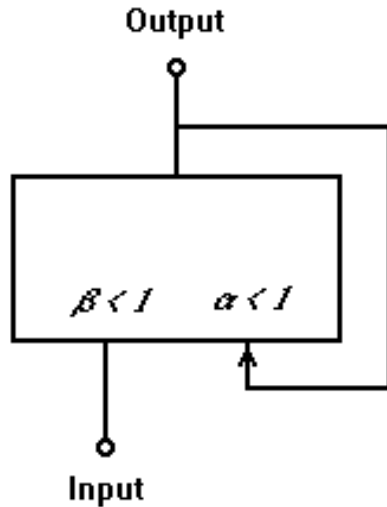

α = probability for the WM to continue firing

β = probability for a stimulus to initiate WM firing

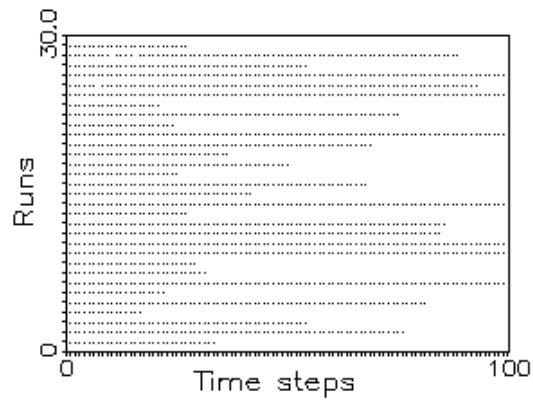

Spike trains sample

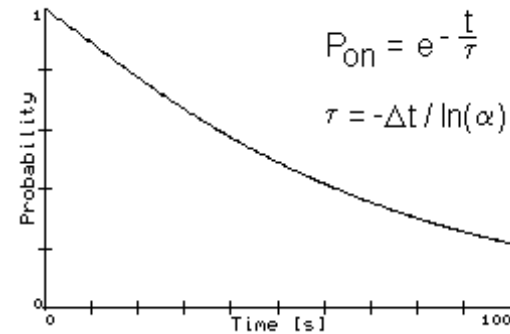

Probability of finding the WM in an active state

Probabilistic behaviour: Delayed Matching to Sample

(Bauer & Fuster, 1976; Fuster et al., 1981)

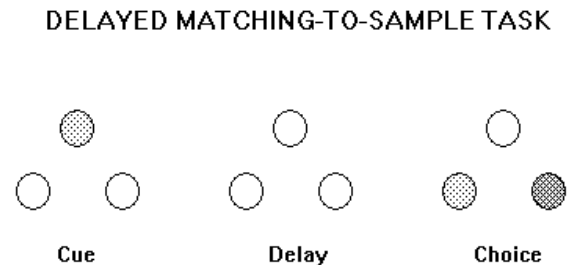

Working memory decays

as shown by **average** performance curves

The subjects give either **correct** or **incorrect** responses.

The **fraction** of correct responses decreases with time.

-> A model of the **subject** must be stochastic

What neuronal mechanism underlies the stochastic behaviour of subjects?

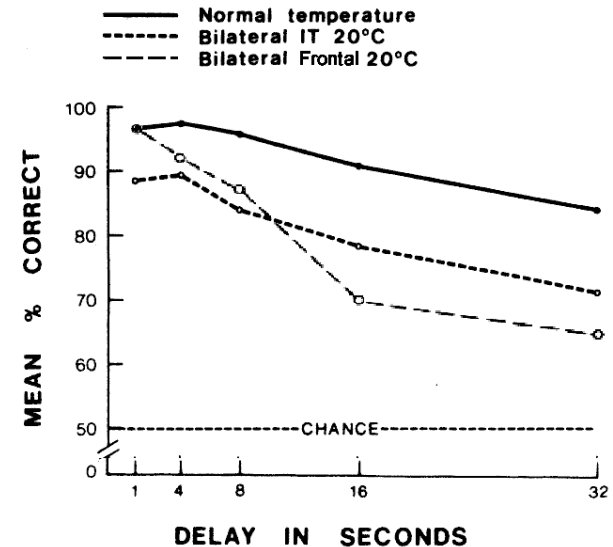

Model reproduces probabilistic behaviour

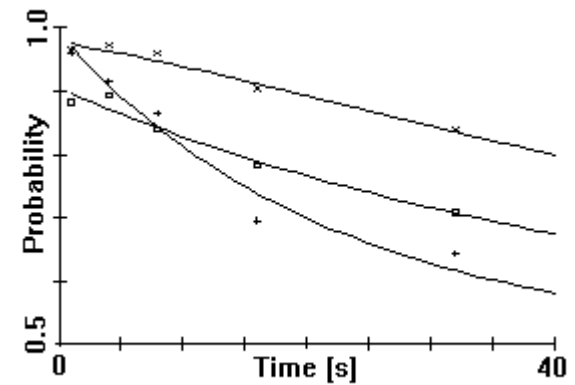
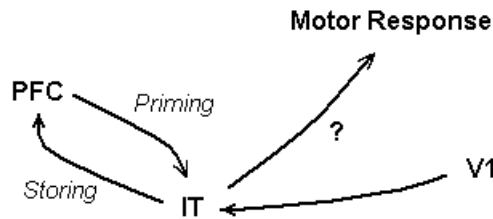
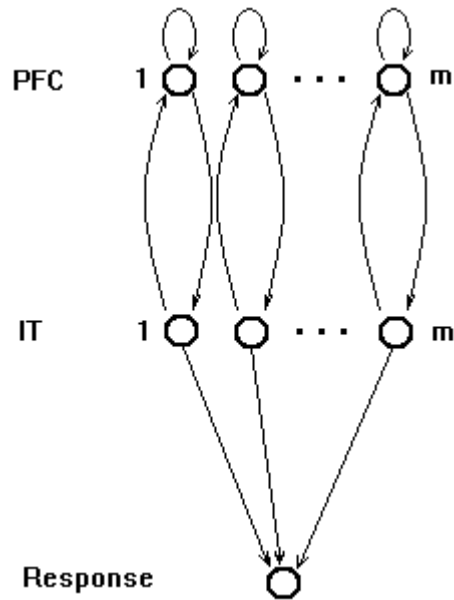

<i>Best fit:</i>	<i>M</i>	<i>Threshol d</i>	τ (s)	β	Tot. Sq. Error
Normal	2	1	52.4	0.80	0.00039
PFC 20°C	2 (fixed)	1 (fixed)	16.8	0.74	0.0041
IT 20°C	2 (fixed)	1 (fixed)	36.7	0.55	0.00068
Normal	1 (fixed)	1	93	0.97	0.00055
PFC 20°C	1	1	22.4	0.98	0.0019
IT 20°C	1	1	48	0.81	0.00066

Cue presented -> Initiate PFC activity

Delay period: PFC decays or not.

Choice: Two stimuli represented in IT.

Decision rule:

IF number of primed neurons \geq threshold	→ Correct pattern selected
ELSE	→ Select at random (50% correct)

Probabilistic behaviour: Relative Recency Discrimination

(Miller et al., 1996)

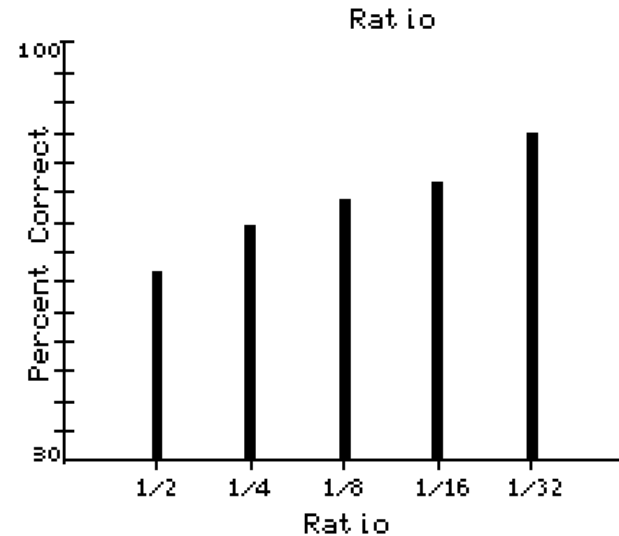
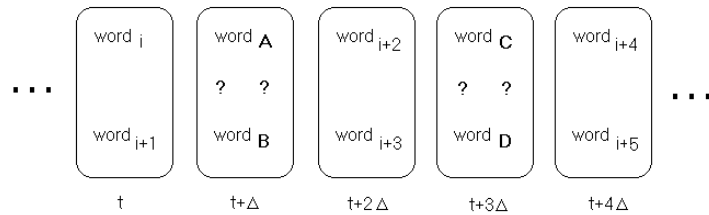

A series of cards are presented.

When a test card occurs, the subject

decides which one of the two items was more recent in the series.

The performance is best when the two items have very different recencies,

e.g. recency ratio = 1/32.

Can a stochastic trace model explain the probabilistic behaviour of subjects?

Model reproduces probabilistic behaviour

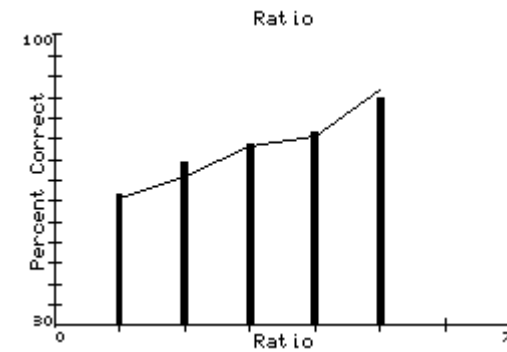
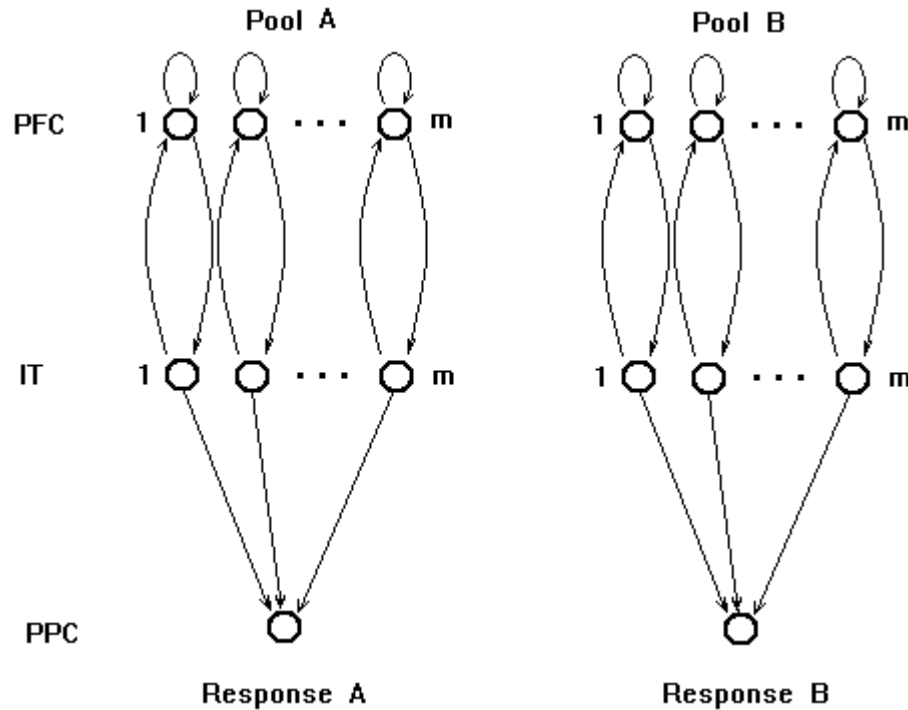

<i>Best fit:</i>	m	τ (sec)	β	Tot. sq. error
Concrete words	8 (free)	21.7	0.23	0.00066
	2 (fixed)	23.4	0.72	0.00087
	1 (fixed)	30.4	1	0.00170
Drawings	8 (fixed)	15.3	0.26	0.00180
	2 (fixed)	17.6	0.79	0.00130
	1 (free)	27.4	1	0.00110

Decision rules (A: most recent pattern)

IF $N_A > N_B$	→ Correct pattern selected: A
IF $N_A < N_B$	→ Error (B selected as most recent)
IF $N_A = N_B$	→ Select at random (50% correct)

Probabilistic behaviour: Oculomotor Delayed Spatial Response

(Ploner et al., 1998)

Subjects make delayed saccades to targets with excentricity ± 10 deg., ± 15 deg., ± 20 deg.

Delays up to 30 sec.

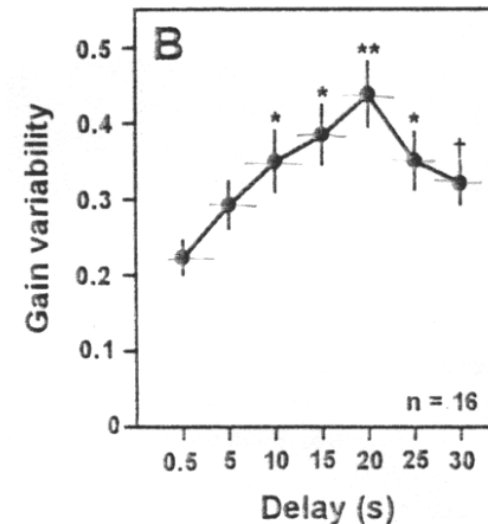
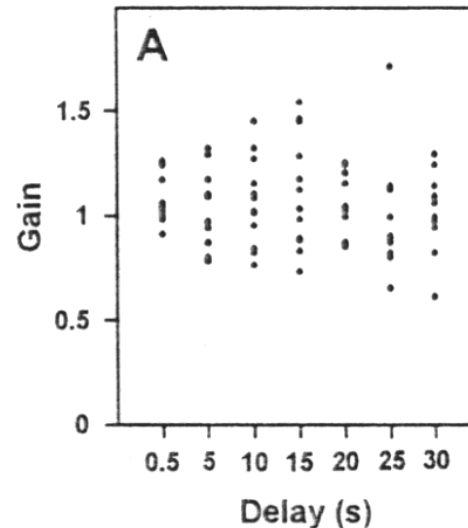
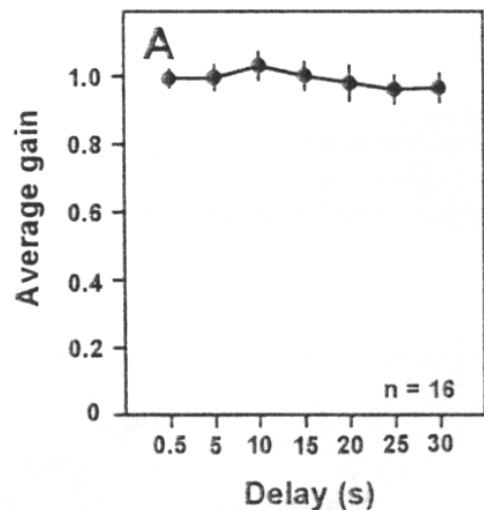

In average, saccades are to the correct excentricity, but the **variability** increases with the delay (up to 20 sec !).

Can a stochastic trace explain the increase in variability ?

Model reproduces the variability of the behaviour

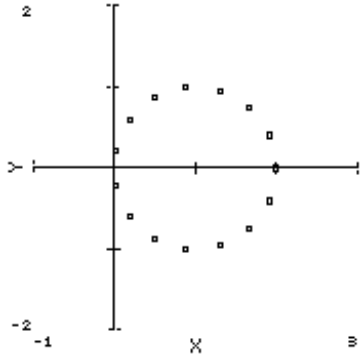

A pool of WM neurons codes for the direction of the saccade (similar to Georgopoulos et al, 1984).

Each WM neurons codes for a different target position of the saccade.

The centre-of-gravity average in the pool points to the correct position.

As WM neurons decay, a diminishing number of neurons in the pool contribute to the average -> variability increase.

Best fit:

4 neurons in the pool

$\tau = 50$ sec, $\beta = 0.9$

